

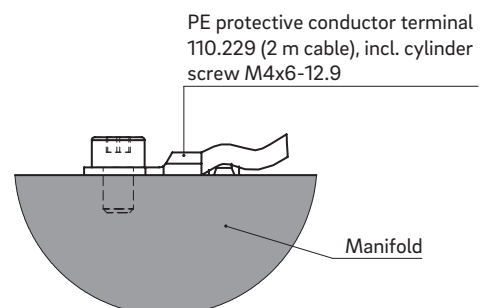

Cross manifold type KCP4/KDP4

Manifold length (VL) 240/270/300

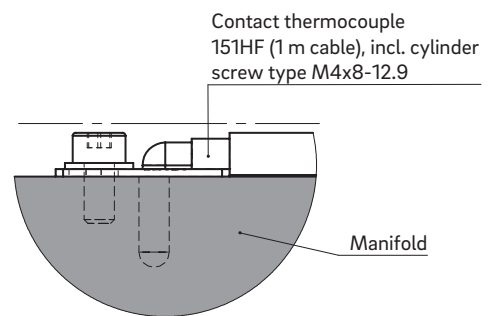
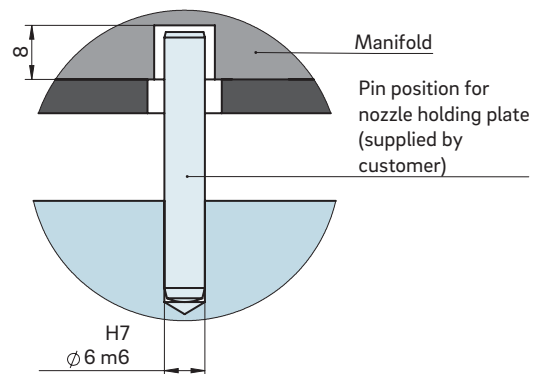

TECHNICAL DATA

KCP4/KDP4 240/270/300

Manifold height (VH) KCP: 36 mm
KDP: 46 mm

Operating voltage 230 V_{AC} *

Manifold length (VL)	240	270	300
Pin position (SP)	81.0	87.5	101.0
Dimension B	127.0	156.6	187.0
Control circuits	2	2	2
Power (watts) per control circuit	2 × 1000	2 × 1350	2 × 1500

*Volts alternating current

WEBCODE
25090



INSTALLATION

Nozzle tip view

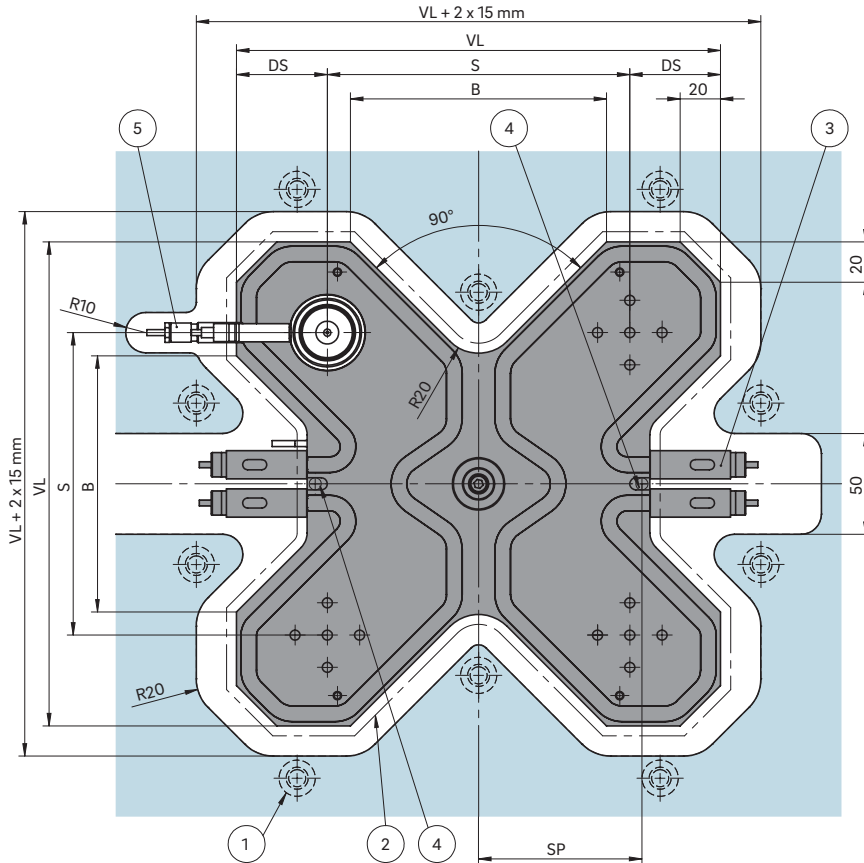

DS Edge distance:
 a. min. 35.0 with nozzle size ≤ 6
 b. min. 45.0 with nozzle size 8 or 10
 c. min. 50.0 with nozzle size ≥ 12

S Pitch between the nozzles

- ① Screw connection close to manifold
- ② High-temperature insulation plate
- ③ Heating connections
- ④ Possible pin position
- ⑤ Opening and plug location dependent upon nozzle type

Manifold height (VH)

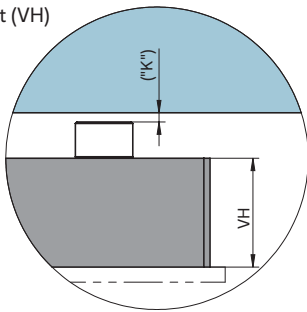

Design examples/Balancing

Type		KCP = 36 (VH) Melt channel Ød in mm	KDP = 46 (VH) Melt channel Ød in mm	Number of drops
K_P4B		≤ 10	≥ 12 to 16	4
		DS min. 35	DS min. 50	

B = balanced

Dimension "K" required for heat expansion is to be ensured by grinding the pressure piece (12 + 0.1 mm)! Determine the difference between the height of the manifold system and the height of the frame plate when installed! ΔT specifies the temperature differential between the processing temperature and the mould temperature!

VH	ΔT (°C)	100	150	200	250	300	350
36 mm	K (mm)	0.021	0.059	0.098	0.137	0.177	0.217
46 mm	K (mm)	0.033	0.078	0.124	0.170	0.218	0.264