

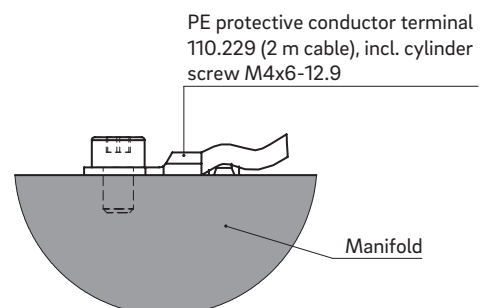

Straight manifold type GCP

Manifold length (VL) 410-510

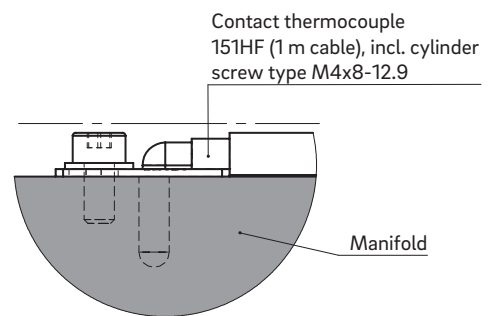
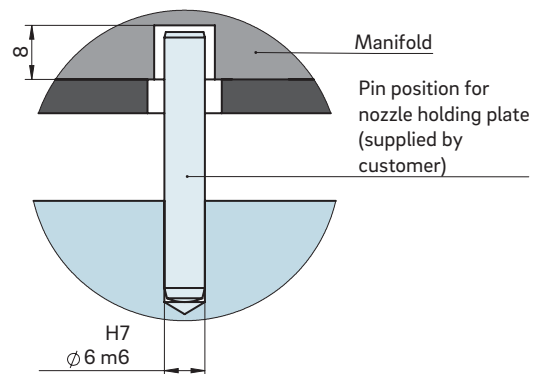

TECHNICAL DATA

GCP VL 410-510

Manifold height (VH)	36 mm		
Operating voltage	230 V _{AC} *		
Manifold length (VL)	410	460	510
Control circuits	2	2	2
Power (watts) per control circuit	2 × 850	2 × 950	2 × 1000

*Volts alternating current

WEBCODE
25020



INSTALLATION

Nozzle tip view

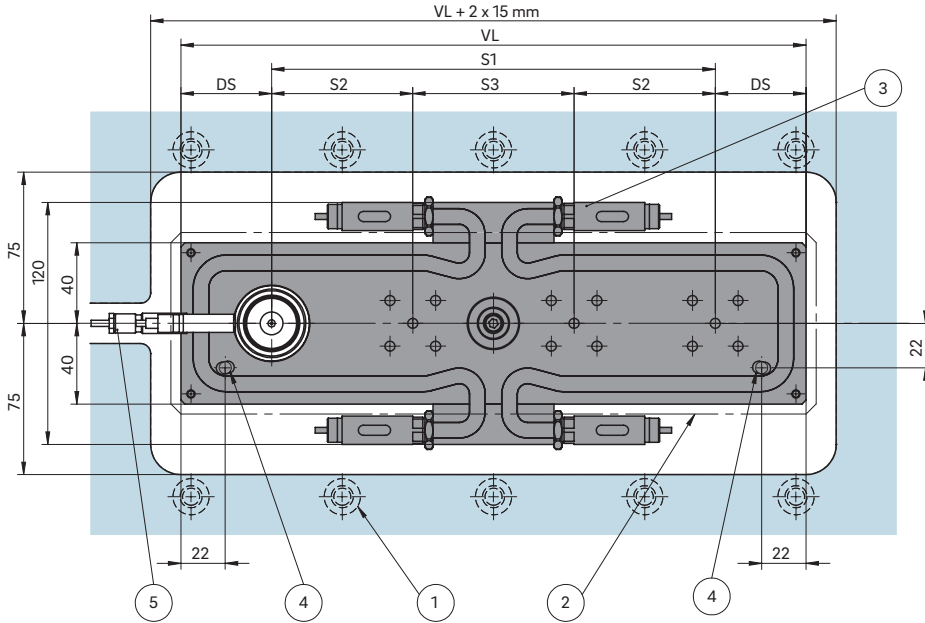

DS Edge distance:
 a. min. 35.0 with nozzle size ≤ 6
 b. min. 45.0 with nozzle size 8

S1 Largest pitch (max. pitch)
 S2 Pitch between the nozzles (min./max. pitch)
 S3 Pitch between the nozzles, taking connecting element and spacer into account (min./max. pitch)

- ① Screw connection close to manifold
- ② High-temperature insulation plate
- ③ Heating connections
- ④ Possible pin position
- ⑤ Opening and plug location dependent upon nozzle type

Manifold height (VH)

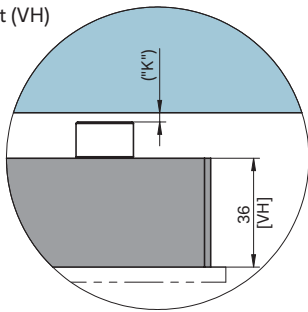

Dimension "K" required for heat expansion is to be ensured by grinding the pressure piece (12 + 0.1 mm)! Determine the difference between the height of the manifold system and the height of the frame plate when installed! ΔT specifies the temperature differential between the processing temperature and the mould temperature!

VH	ΔT (°C)	100	150	200	250	300	350
36 mm	K (mm)	0.021	0.059	0.098	0.137	0.177	0.217

Design examples/Balancing

Type		Melt channel Ød in mm	Number of drops
GCP1B		≤ 10	1
GCP2B		≤ 10	2
GCP3-		≤ 10	3
GCP4B		≤ 8	4
GCP6T		≤ 8	6
GCP8T		≤ 8	8

B = balanced T = partially balanced - = not balanced